

REFER TO SHEET A-401 FOR
ENLARGED BATHROOM PLANS
& ELEVATIONS. REFER TO
ROOM 211 ELEVATIONS FOR
TYPICAL STORAGE AND CLOSET
FINISHES

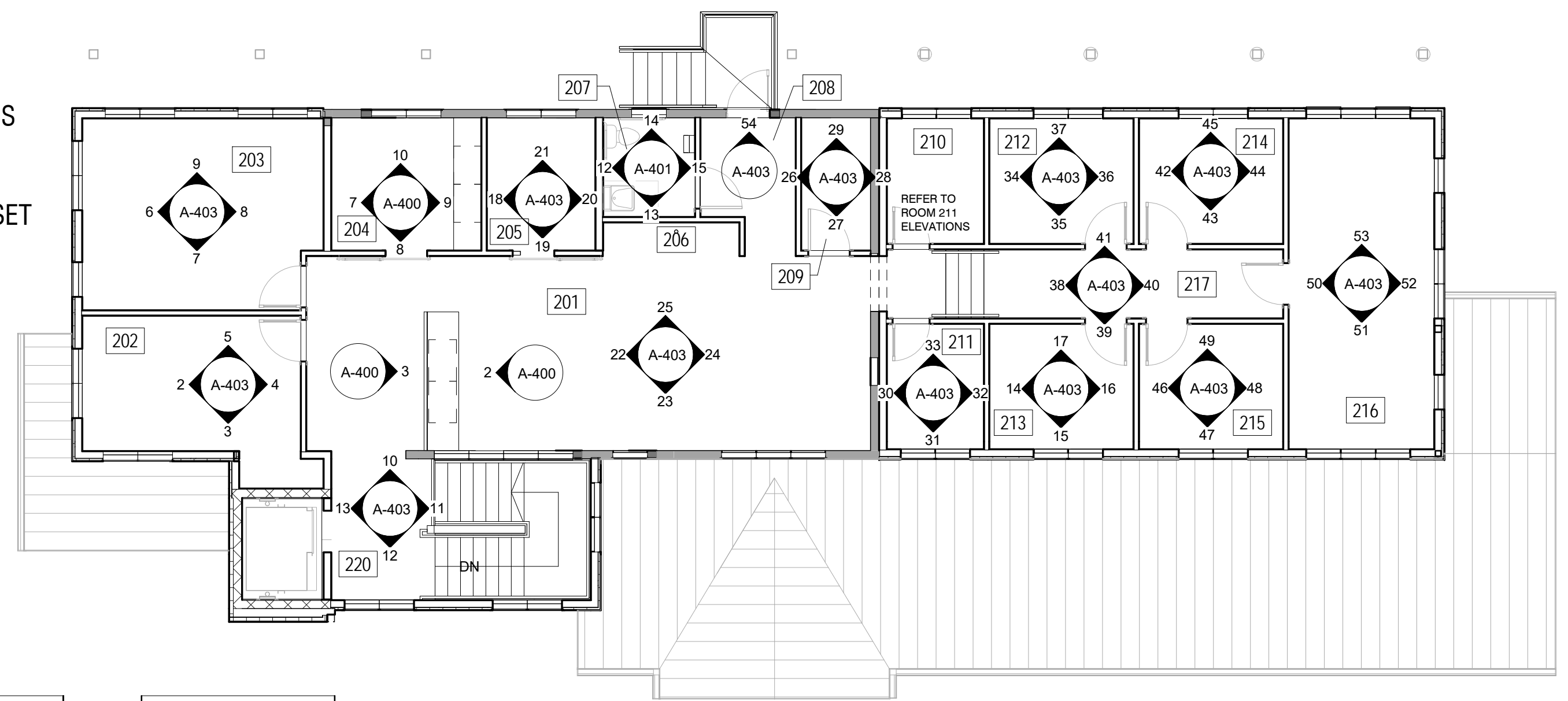

1 SECOND FLOOR - KEY PLAN
1/8" = 1'-0"

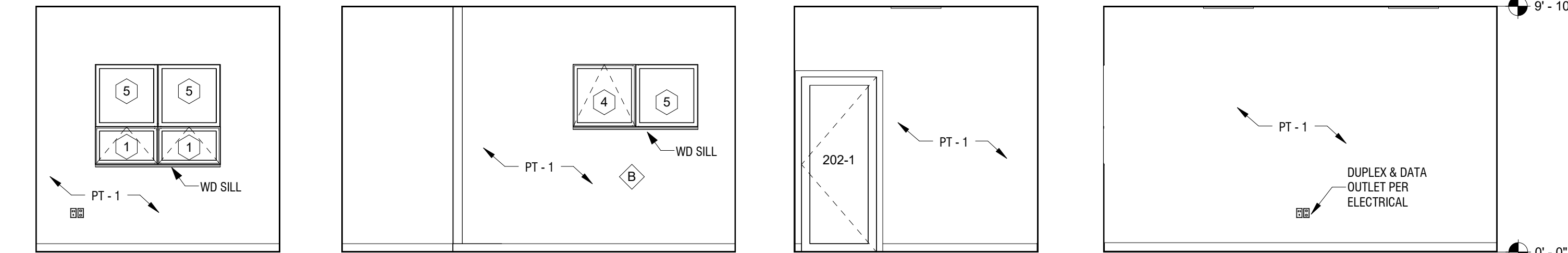

2 COMMUNITY DEV 202 WEST 1/4" = 1'-0"
3 COMMUNITY DEV 202 SOUTH 1/4" = 1'-0"
4 COMMUNITY DEV 202 EAST 1/4" = 1'-0"
5 COMMUNITY DEV 202 NORTH 1/4" = 1'-0"

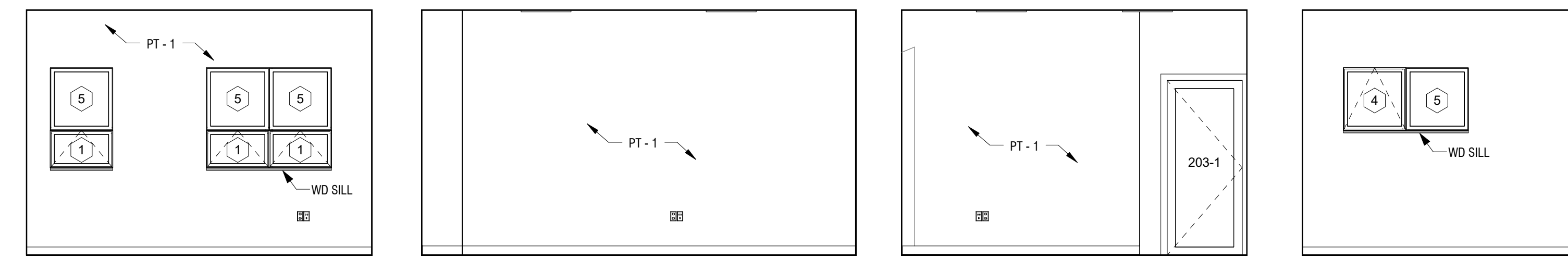

6 VILLAGE ADMIN 203 WEST 1/4" = 1'-0"
7 VILLAGE ADMIN 203 SOUTH 1/4" = 1'-0"
8 VILLAGE ADMIN 203 EAST 1/4" = 1'-0"
9 VILLAGE ADMIN 203 NORTH 1/4" = 1'-0"

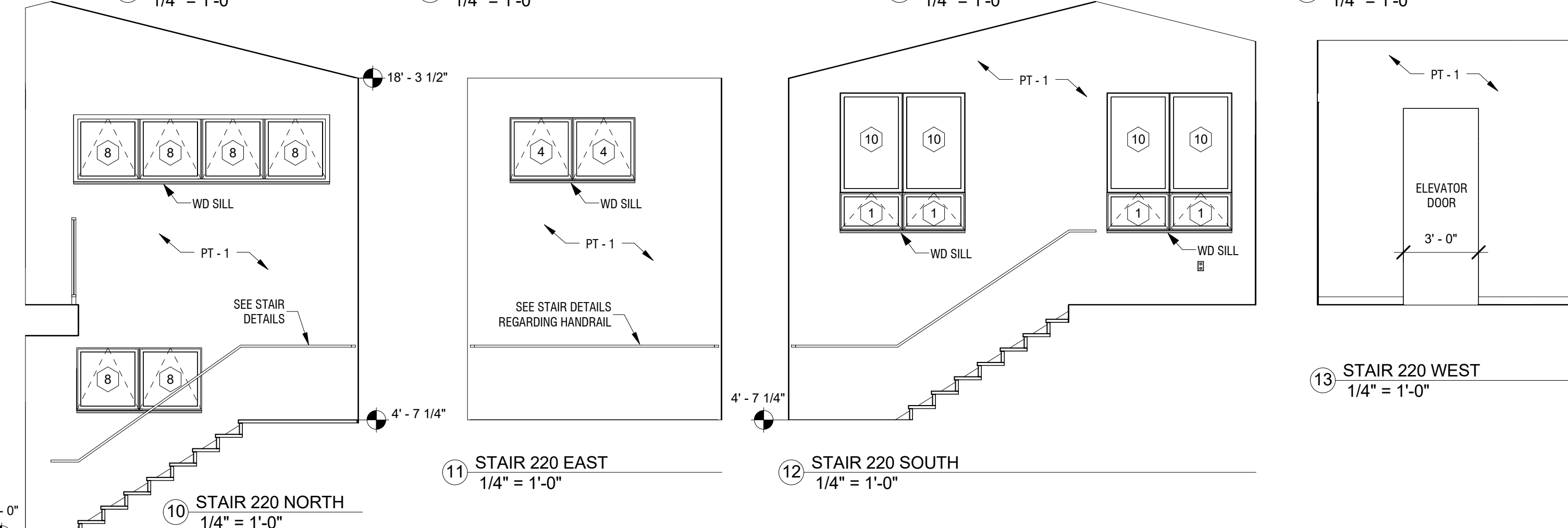

10 STAIR 220 NORTH 1/4" = 1'-0"
11 STAIR 220 EAST 1/4" = 1'-0"
12 STAIR 220 SOUTH 1/4" = 1'-0"

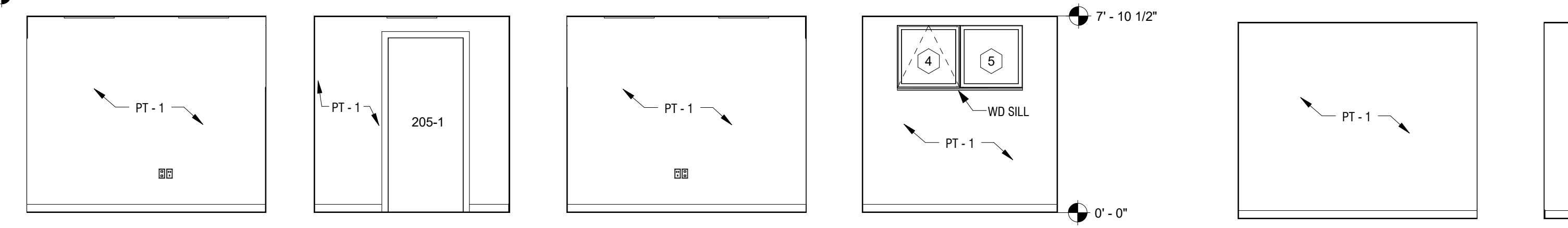

18 WORK STATION 205 WEST 1/4" = 1'-0"
19 WORK STATION 205 SOUTH 1/4" = 1'-0"
20 WORK STATION 205 EAST 1/4" = 1'-0"
21 WORK STATION 205 NORTH 1/4" = 1'-0"

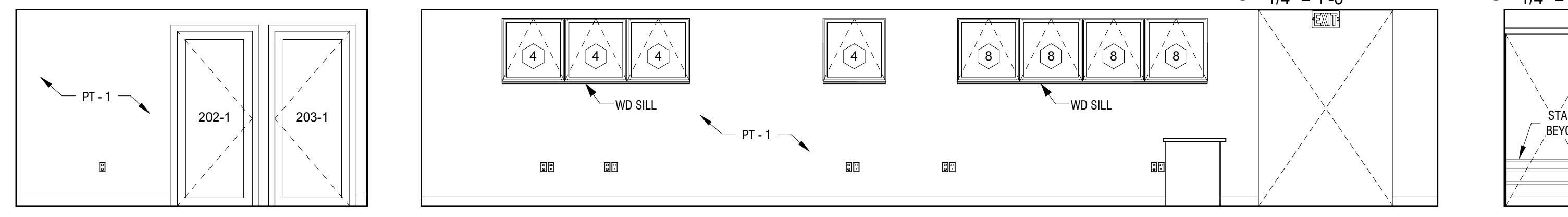

26 SERVER / IT 209 WEST 1/4" = 1'-0"
27 SERVER / IT 209 SOUTH 1/4" = 1'-0"
28 SERVER / IT 209 EAST 1/4" = 1'-0"
29 SERVER / IT 209 NORTH 1/4" = 1'-0"

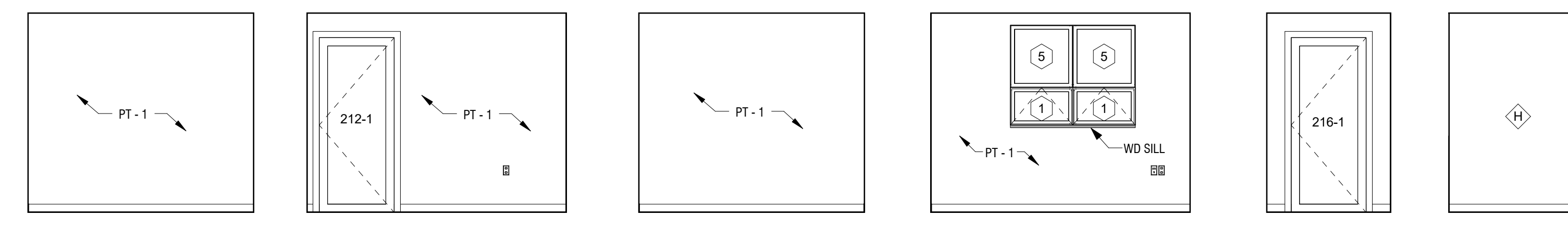

22 PUBLIC WORKS 201 WEST 1/4" = 1'-0"
23 PUBLIC WORKS 201 SOUTH 1/4" = 1'-0"
24 PUBLIC WORKS 201 EAST 1/4" = 1'-0"
25 PUBLIC WORKS 201 NORTH 1/4" = 1'-0"

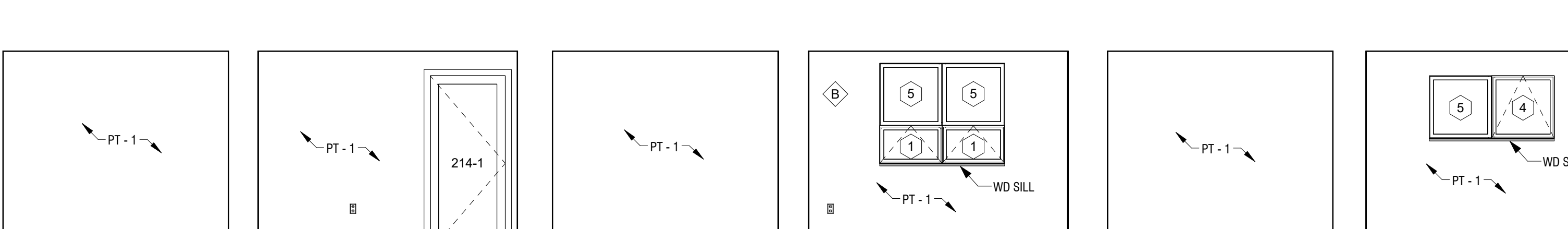

34 OFFICE 212 WEST 1/4" = 1'-0"
35 OFFICE 212 SOUTH 1/4" = 1'-0"
36 OFFICE 212 EAST 1/4" = 1'-0"
37 OFFICE 212 NORTH 1/4" = 1'-0"

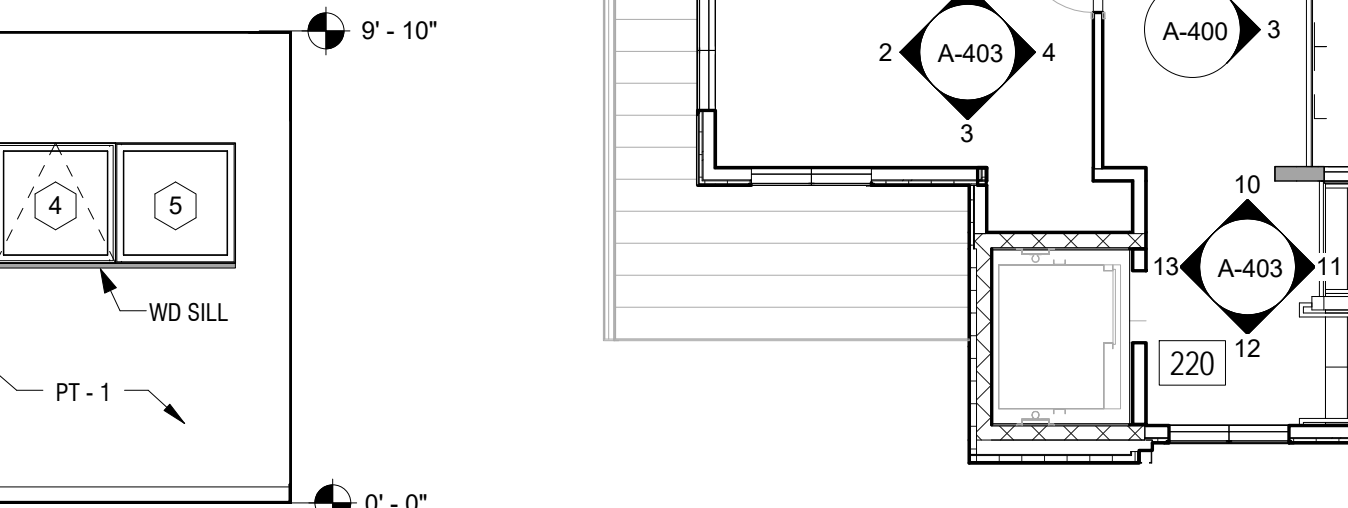

30 STORAGE 211 WEST 1/4" = 1'-0"
31 STORAGE 211 SOUTH 1/4" = 1'-0"
32 STORAGE 211 EAST 1/4" = 1'-0"
33 STORAGE 211 NORTH 1/4" = 1'-0"

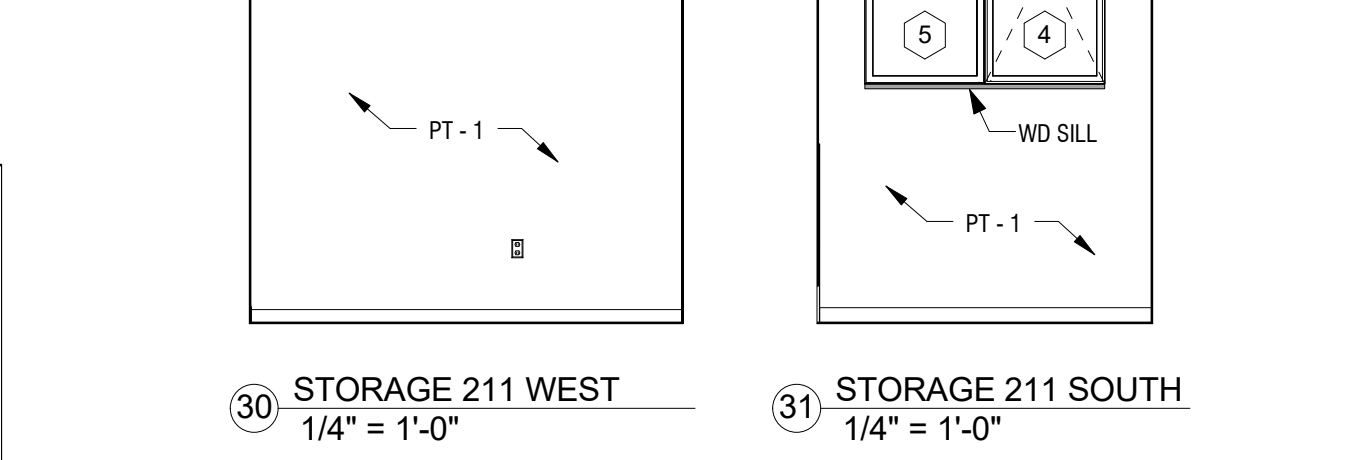

13 STAIR 220 WEST 1/4" = 1'-0"

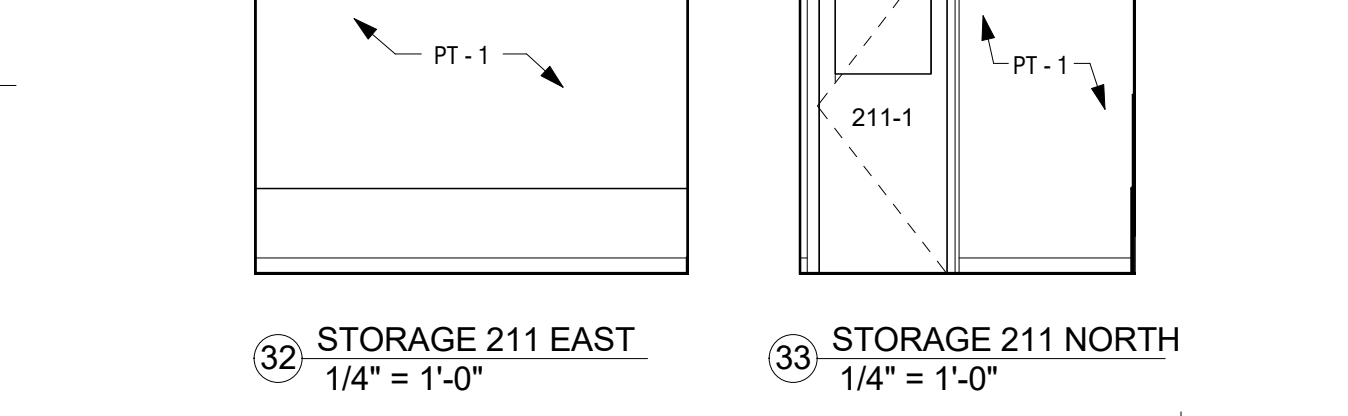

50 CONFERENCE 216 WEST 1/4" = 1'-0"
51 CONFERENCE 216 SOUTH 1/4" = 1'-0"
52 CONFERENCE 216 EAST 1/4" = 1'-0"
53 CONFERENCE 216 NORTH 1/4" = 1'-0"

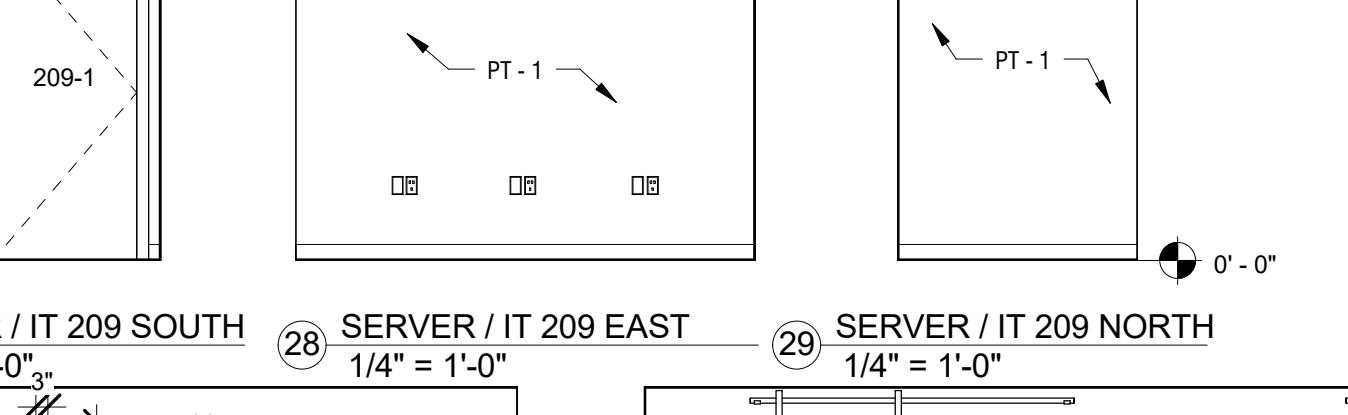

18 WORK STATION 205 WEST 1/4" = 1'-0"
19 WORK STATION 205 SOUTH 1/4" = 1'-0"
20 WORK STATION 205 EAST 1/4" = 1'-0"
21 WORK STATION 205 NORTH 1/4" = 1'-0"

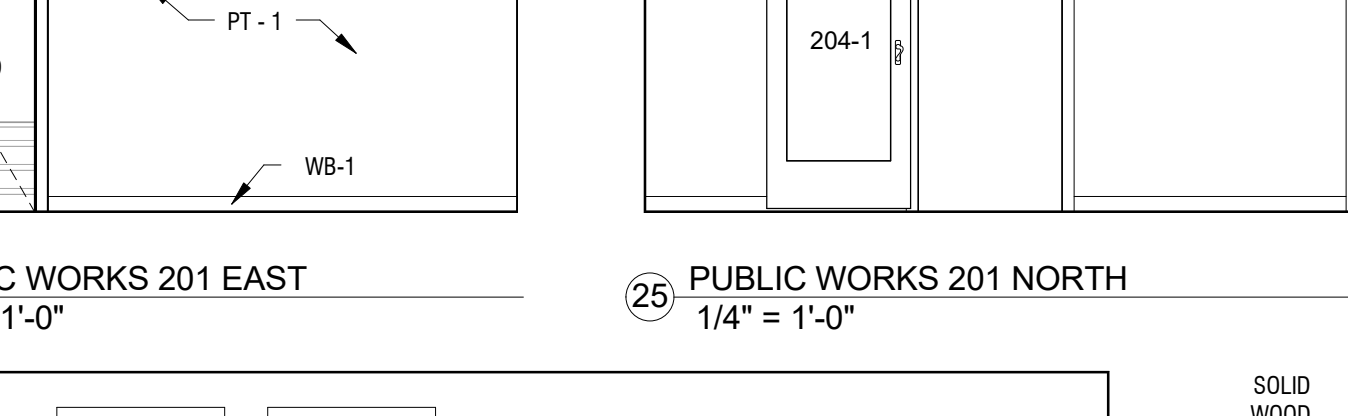

26 SERVER / IT 209 WEST 1/4" = 1'-0"
27 SERVER / IT 209 SOUTH 1/4" = 1'-0"
28 SERVER / IT 209 EAST 1/4" = 1'-0"
29 SERVER / IT 209 NORTH 1/4" = 1'-0"

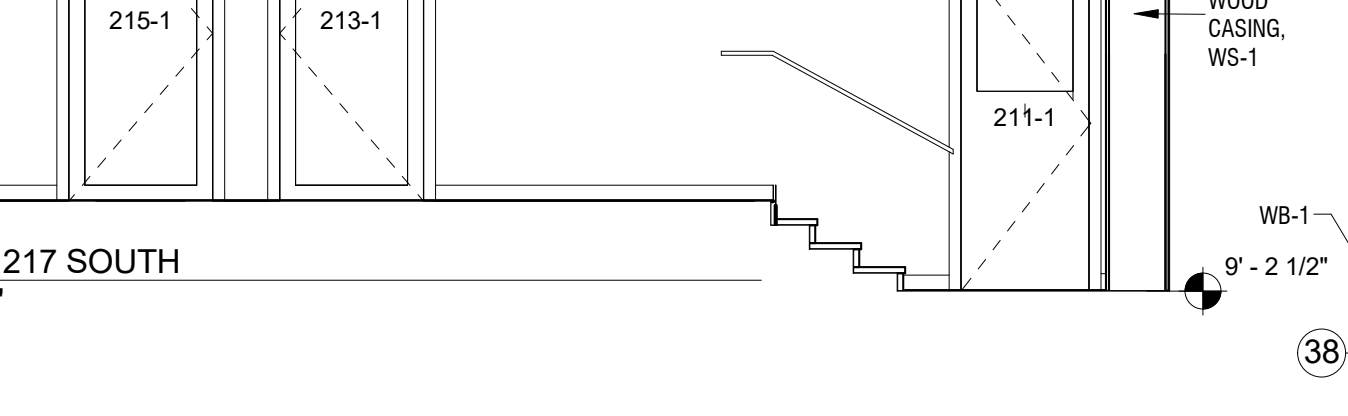

22 PUBLIC WORKS 201 WEST 1/4" = 1'-0"
23 PUBLIC WORKS 201 SOUTH 1/4" = 1'-0"
24 PUBLIC WORKS 201 EAST 1/4" = 1'-0"
25 PUBLIC WORKS 201 NORTH 1/4" = 1'-0"

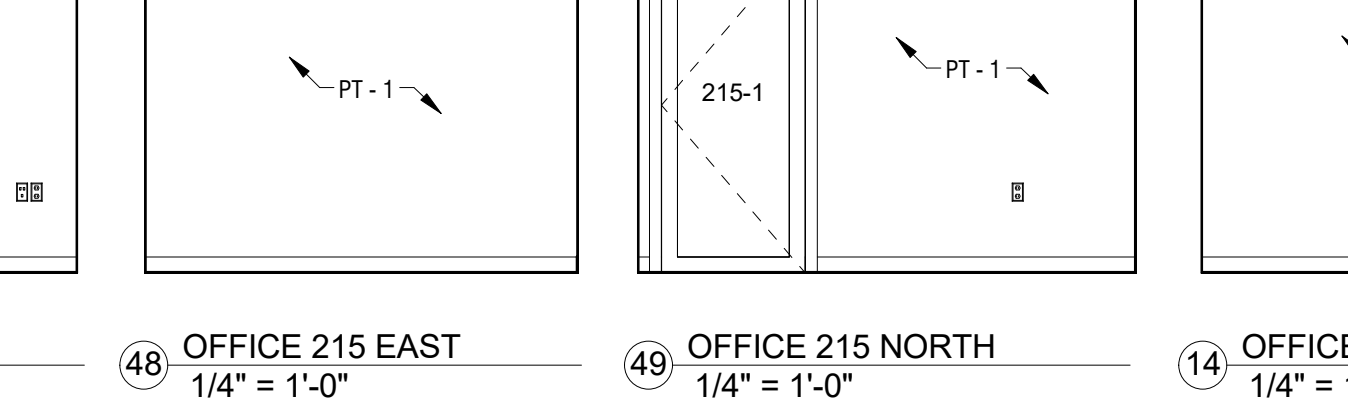

34 OFFICE 212 WEST 1/4" = 1'-0"
35 OFFICE 212 SOUTH 1/4" = 1'-0"
36 OFFICE 212 EAST 1/4" = 1'-0"
37 OFFICE 212 NORTH 1/4" = 1'-0"

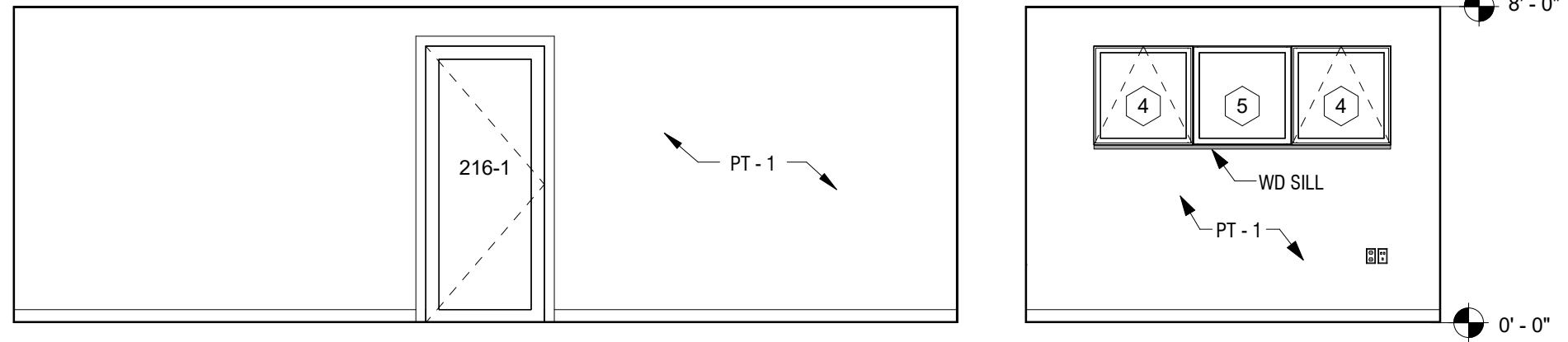

50 CONFERENCE 216 WEST 1/4" = 1'-0"
51 CONFERENCE 216 SOUTH 1/4" = 1'-0"
52 CONFERENCE 216 EAST 1/4" = 1'-0"
53 CONFERENCE 216 NORTH 1/4" = 1'-0"

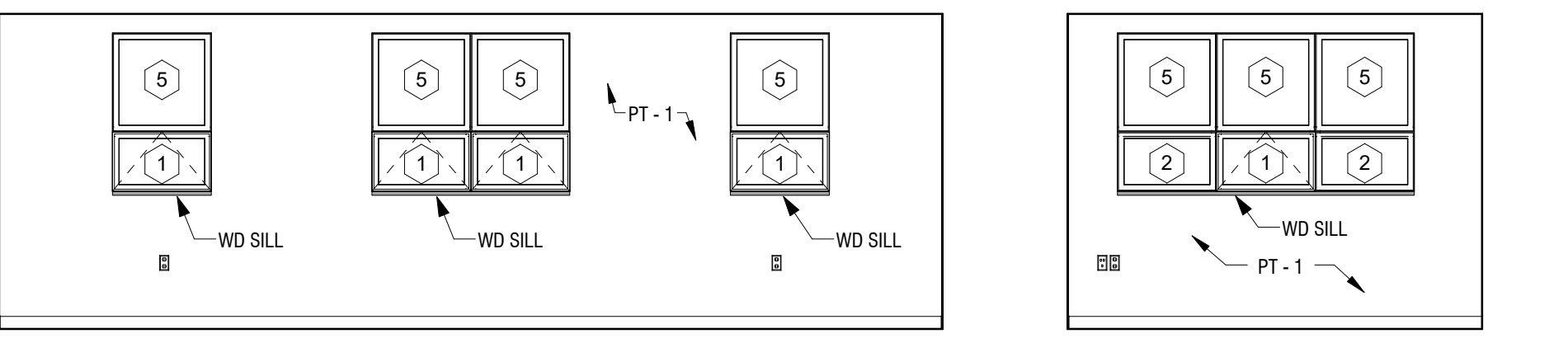

50 CONFERENCE 216 WEST 1/4" = 1'-0"
51 CONFERENCE 216 SOUTH 1/4" = 1'-0"
52 CONFERENCE 216 EAST 1/4" = 1'-0"
53 CONFERENCE 216 NORTH 1/4" = 1'-0"

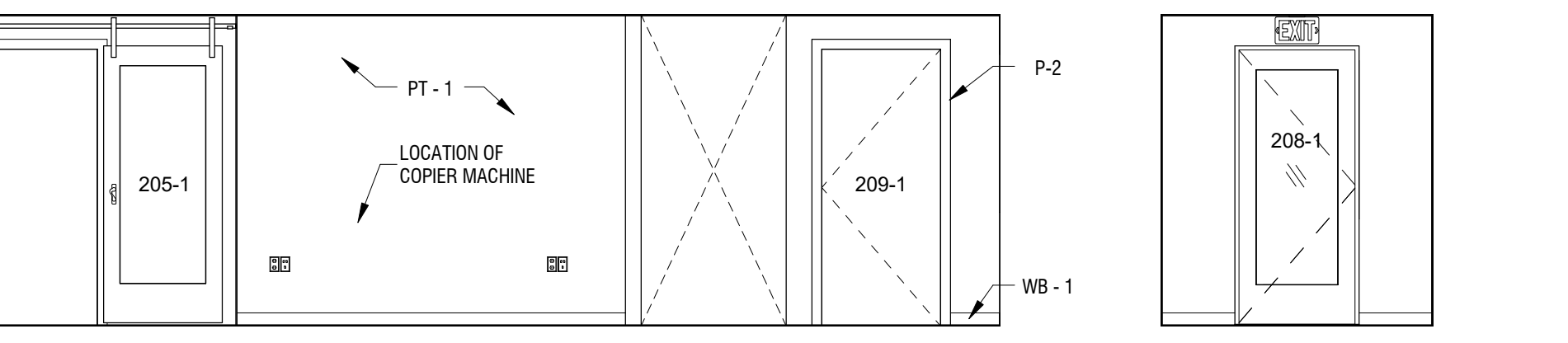

22 PUBLIC WORKS 201 WEST 1/4" = 1'-0"
23 PUBLIC WORKS 201 SOUTH 1/4" = 1'-0"
24 PUBLIC WORKS 201 EAST 1/4" = 1'-0"
25 PUBLIC WORKS 201 NORTH 1/4" = 1'-0"

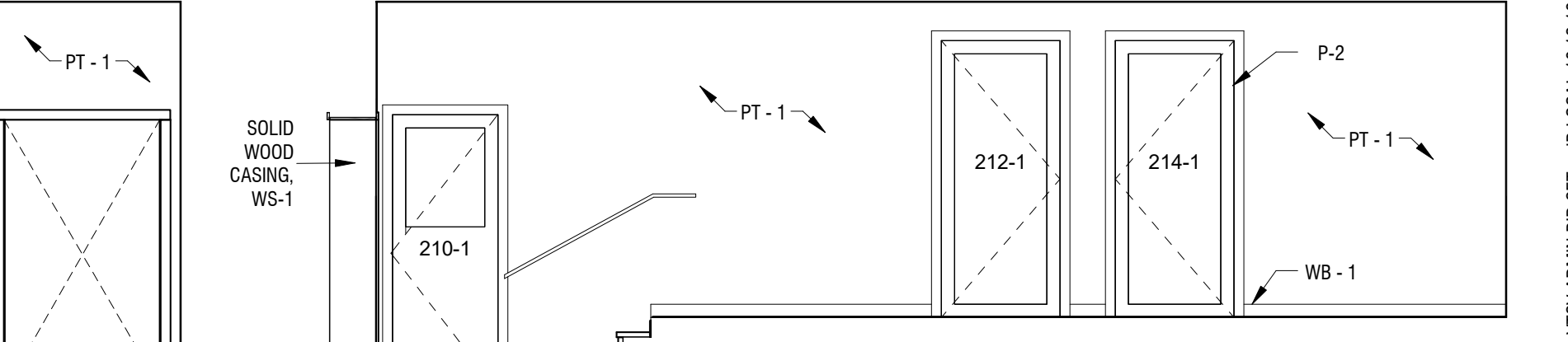

34 OFFICE 212 WEST 1/4" = 1'-0"
35 OFFICE 212 SOUTH 1/4" = 1'-0"
36 OFFICE 212 EAST 1/4" = 1'-0"
37 OFFICE 212 NORTH 1/4" = 1'-0"

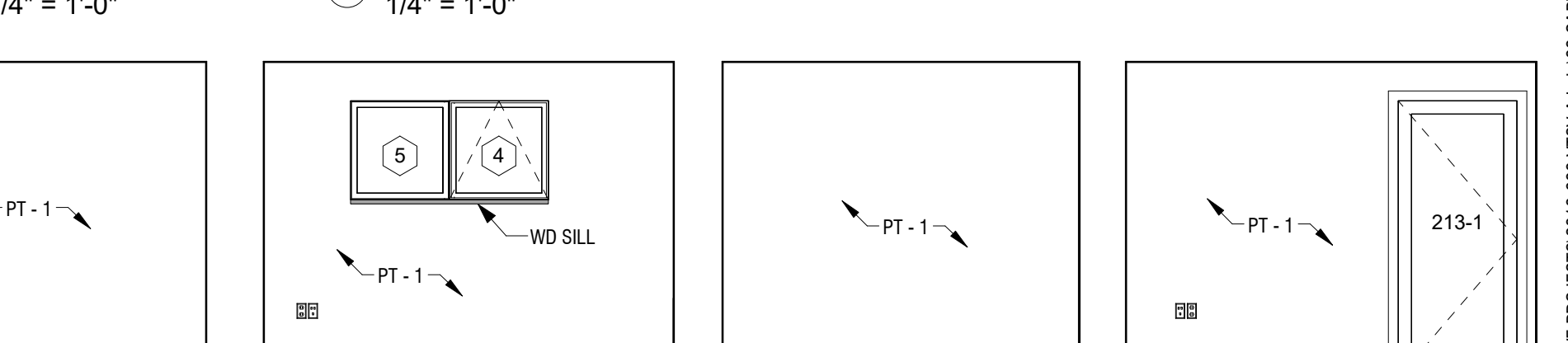

34 OFFICE 212 WEST 1/4" = 1'-0"
35 OFFICE 212 SOUTH 1/4" = 1'-0"
36 OFFICE 212 EAST 1/4" = 1'-0"
37 OFFICE 212 NORTH 1/4" = 1'-0"

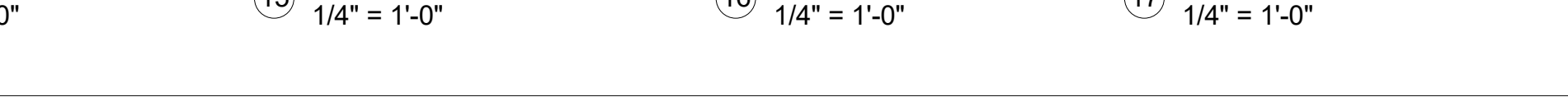

34 OFFICE 212 WEST 1/4" = 1'-0"
35 OFFICE 212 SOUTH 1/4" = 1'-0"
36 OFFICE 212 EAST 1/4" = 1'-0"
37 OFFICE 212 NORTH 1/4" = 1'-0"